

# BOMBAS CENTRIFUGAS

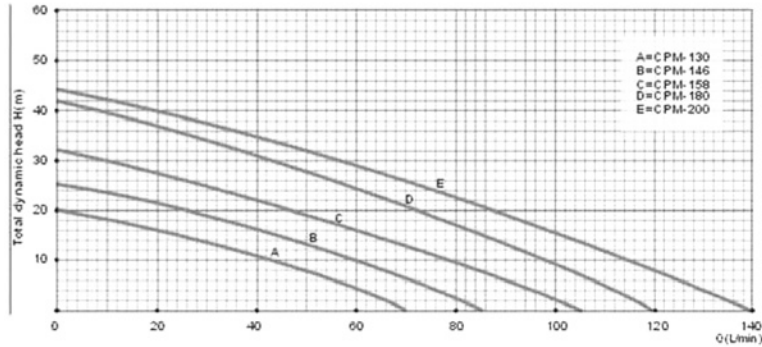

MODELO	POTENCIA		AMPERE	RPM	Q.MAX(l/min)	H.MAX(m)	SUC.MAX(m)	PESO(Kg)
	HP	KW	1-220V					
CPM-130	0.5	0.37	2.7	2850	70	20	7	9.5
CPM-146	0.75	0.55	3.6	2850	85	25	7	12.6
CPM-158	1	0.75	5	2850	105	32	7	14.7
CPM-180	1.5	1	7.5	2850	120	42	7	23
CPM-200	2	1.5	9.6	2850	140	44	7	26

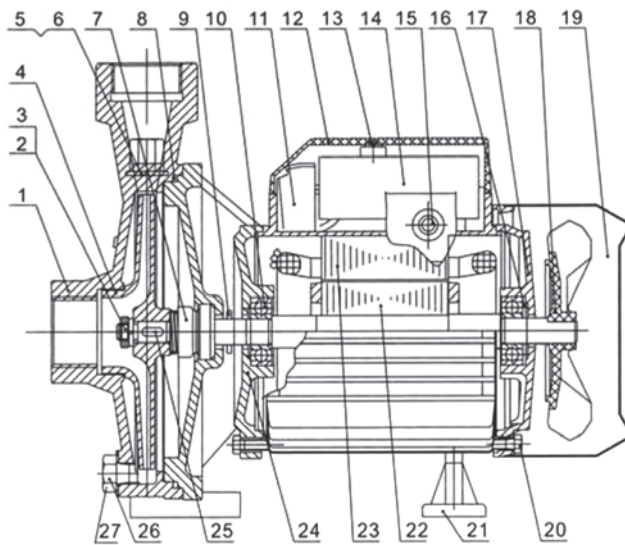

N.	Descripción	Material	N.	Descripción	Material
1	Cuerpo de bomba	C.L.-HT200	15	Prensa cable	NBR
2	Chavetero	SS 420	16	Tornillo fijación	65Mn
3	Tuerca de protección	SS 420	17	Tapa motor	EL-ZL 102
4	Turbina	Brass or C.I.	18	Ventilador	ABS
5	Tapón cebar	Brass H59	19	Cubre ventilador	A3
6	Arandela de presión	NBR	20	Traba cubre ventilador	Steel-A3
7	Sello mecánico	SS304&NBR	21	Pie	
8	Oring	NBR	22	Rotor	
9	Guarda de protección	NBR	23	Stator	
10	Cojinete		24	Frente de bomba	C.I.HT200
11	Bornera	ABS	25	Chavetero	SS 420
12	Tapa bornera	ABS	26	Tapón drenaje	H59
13	Tornillo	Steel-A3	27	Arandela de presión	NBR
14	Capacitor	CCB60	28		